

称重传感器 LOAD CELL

SBC/SBC-SS 称重传感器

SBC/SBC-SS Load Cell



- Maximum capacity (E_{max}) 额定载荷 (t):
0.5, 1, 2, 3, 5

Be suitable for the fields of Hopper and Tank Weighing, Belt Scales, and other Chemical, Industries of Foods, Pharmaceuticals, which has huge important on weighing and control.

适用于料罐秤、料斗秤、皮带秤、化工、食品、医药等行业配料称重控制

外形尺寸 Dimensions(in mm)

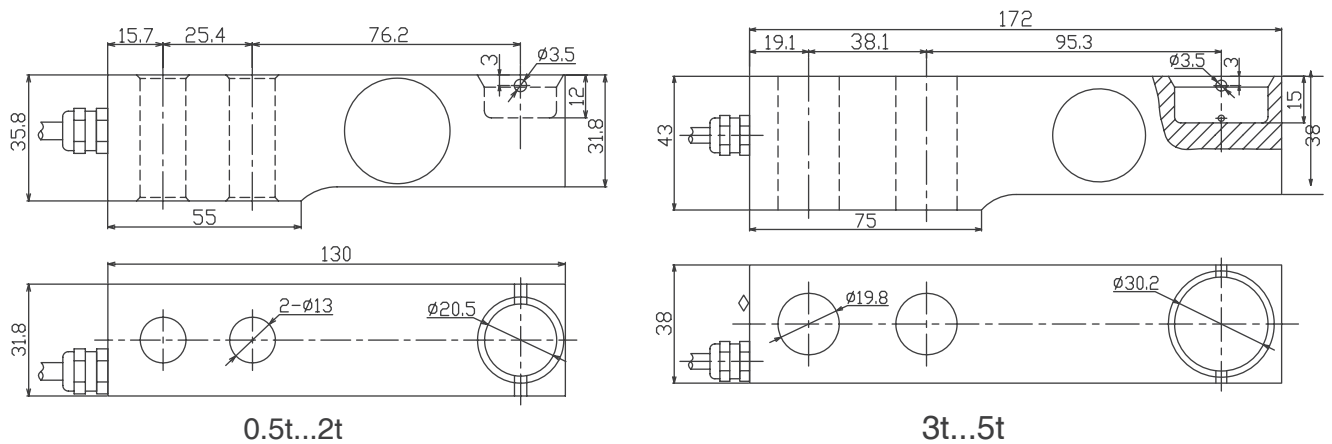

技术参数 Specifications

额定载荷 Rated Load	t	0.5, 1, 2, 3, 5
额定输出 Rated Output	mV/V	2.0±0.005
零点平衡 Zero Balance	%R.O.	±1
综合误差 Comprehensive Error	%R.O.	±0.02
蠕变 (30 分钟) Creep after 30 minutes	%R.O.	±0.02
推荐激励电压 Recommended excitation voltage	VDC	5-12 /15(max)
输入阻抗 Input impedance	Ω	380±10
输出阻抗 Output impedance	Ω	350±5
绝缘阻抗 Insulation resistance	MΩ	≥5000 (50VDC)
安全过载 Safe overload	%R.C.	150
极限过载 Ultimate overload	%R.C.	300
弹性元件材料 Material		Alloy Steel 合金钢 or Stainless Steel 不锈钢
防护等级 Degree of protection		IP67/IP68
电缆线长度 The length of the cable	m	0.5t-2t: 3m 3t-5t: 5m
拧紧力矩 Tightening torque	N·m	0.5t-2t: 98N·m 3t-5t: 275N·m